

# 6-FMXH Series

Front Terminal High Temperature Battery  
6-FMXH-170



SHUANGDENG GROUP

shoto



## Main Applications

- High temperature environment (35°C)
- Outdoor base station
- Floating operation site
- UPS

## Benefits

- Reduce operational cost (less cooling consumption)
- Reduce CO<sub>2</sub> emission
- Secure operation under high temperature up to 55°C
- Double floating life vs. traditional VRLA battery under 35°C

## Dimensions

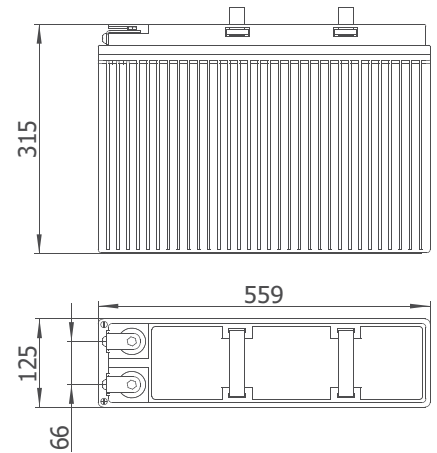

## Technical Parameters

Nominal Voltage	12V
Capacity	170 Ah @10hr to 1.80V per cell @ 25°C(77°F) 175 Ah @10hr to 1.80V per cell @ 35°C(95°F)
Weight	57.5kg(126.77lbs)
Dimensions	Length: 559mm (22.00 in) Width: 125 mm (4.92in) Height: 315mm (12.40 in)
Internal Resistance (full charged)	3.2mΩ
Short-circuit Current	2852 A
Self Discharge @ 35°C(95°F)	Less than 4 % after 30 days storage
Operating Temperature Range	Discharge: -40°C ~ 65°C(-40°F ~ 149°F) Charge: -20°C ~ 45°C(-4°F ~ 113°F) Storage: -20°C ~ 40°C(-4°F ~ 104°F)
Recommended Operating Temperature	15°C ~ 35°C(59°F ~ 95°F)
Recommended Charging Current	34 A
Charging Voltage @35°C(95°F)	Float: 2.23 V/cell Equalize: 2.35 V/cell
Terminal	M6
Container Materials	High Temp ABS/High Temp ABS V0 (Optional)
Capacity Affected by Temperature( C <sub>10</sub> )	105% @ 40°C(104°F) 85% @ 0°C(32°F) 60% @ -20°C(-4°F)
Design Life @35°C(95°F)	10 years

## Certification

- ISO9001:2008
- ISO14001:2004
- GB/T 28001-2011
- UL
- CE

## Technical Features

- Best performance for continuous operation up to 35°C
- Extend service life under high temperature
- Excellent over discharge recovery capability

# 6-FMXH Series

## Front Terminal High Temperature Battery

### 6-FMXH-170



### Constant Current Discharge Characteristics Unit: A (35°C, 95°F)

F.V/Time	30min	1hr	2hr	3hr	4hr	5hr	6hr	8hr	10hr	12hr
1.70V	170.0	96.9	60.3	49.9	40.9	31.7	26.1	20.9	17.4	14.6
1.75V	159.1	93.7	59.6	49.3	39.8	31.3	25.9	20.7	17.2	14.4
1.80V	150.5	91.9	58.9	48.9	39.6	31.0	25.7	20.5	17.0	14.2
1.83V	143.8	88.3	58.2	48.4	39.1	30.5	25.5	20.3	16.8	14.0
1.85V	138.9	85.2	57.6	47.8	38.9	30.3	25.3	20.1	16.6	13.9

### Constant Power Discharge Characteristics Unit: W/cell (35°C, 95°F)

F.V/Time	30min	1hr	2hr	3hr	4hr	5hr	6hr	8hr	10hr	12hr
1.70V	309.4	178.2	116.4	99.9	78.1	62.1	52.3	41.8	34.7	29.0
1.75V	296.5	175	115.8	98.4	76.8	61.4	51.9	41.4	34.4	28.6
1.80V	283.4	173.1	115	96.8	75.9	60.8	51.4	41.2	34.2	28.6
1.83V	274.3	167.2	114.3	95.9	75.4	60.3	51.0	41.0	33.8	28.3
1.85V	268.2	163.4	113.8	95.5	74.7	59.8	50.6	40.8	33.6	28.1

### Performance curve

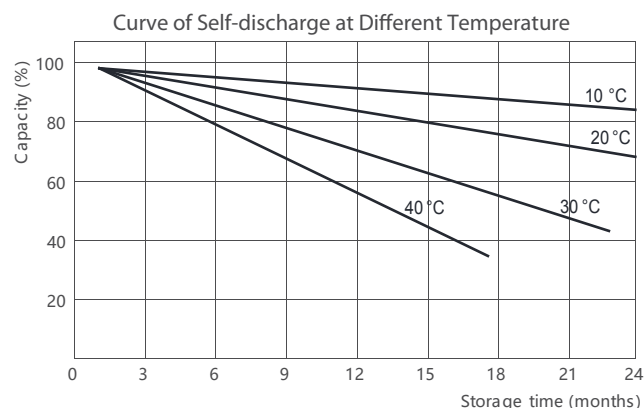
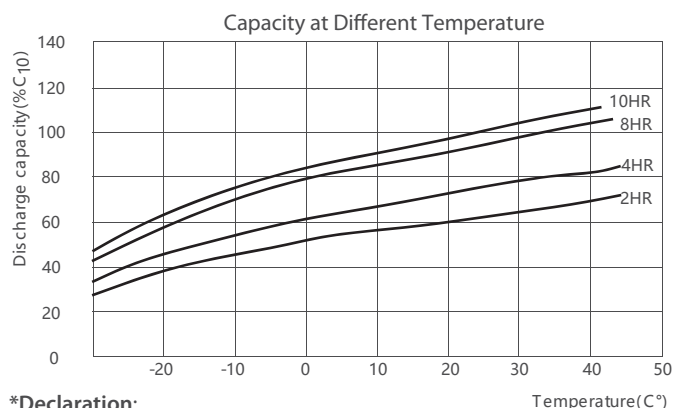
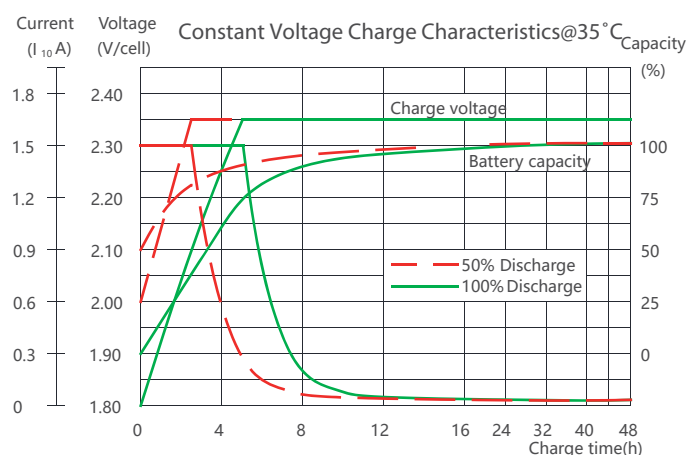
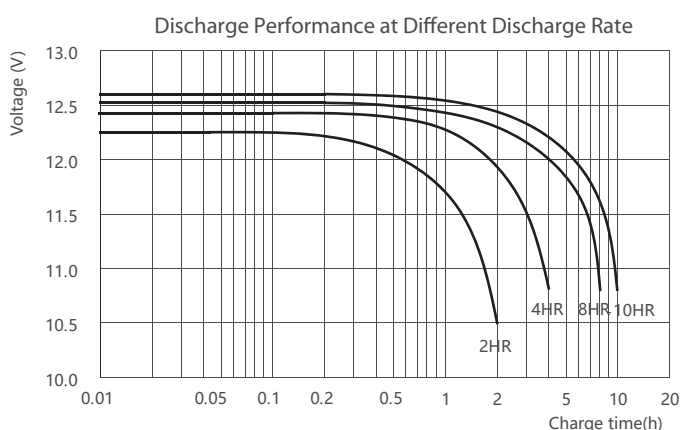

#### \*Declaration:

This information is generally descriptive only and is not intended to make or imply any representation, guarantee or warranty with respect to any cells and batteries. Cell and battery designs/specifications are subject to modification without notice. Contact CHINASHOTO for the latest information.

Welcome to Visit : [www.chinashoto.com](http://www.chinashoto.com)